

Rotary Clamp Cylinder

ø12, ø16, ø20, ø25, ø32, ø40, ø50, ø63

New

Allowable moment of inertia **3 times** higher
 New structure! **NEW MK** series is released!!

Overall length is the same as the existing products! Mounting dimensions are interchangeable with the MK series.

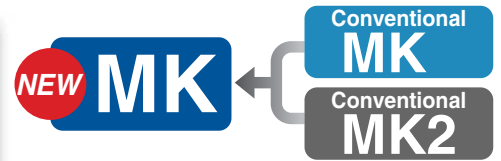

Consolidated to the **New MK series and renewed!**



Possible to mount small auto switches on **4** surfaces

- Auto switches can be mounted on any of the **4** surfaces to suit the installation conditions (**2** surfaces for ø20 and ø25).
- No projection of auto switch



2-color indication solid state auto switch

Accurate setting of the mounting position can be performed without mistakes.

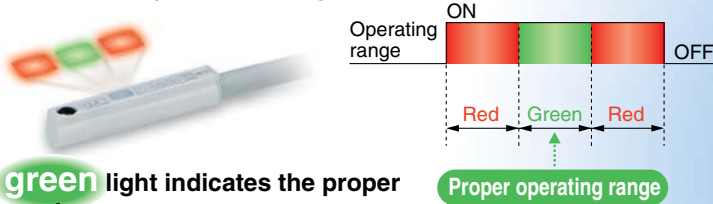

A **green** light indicates the proper operating range.

Application Example

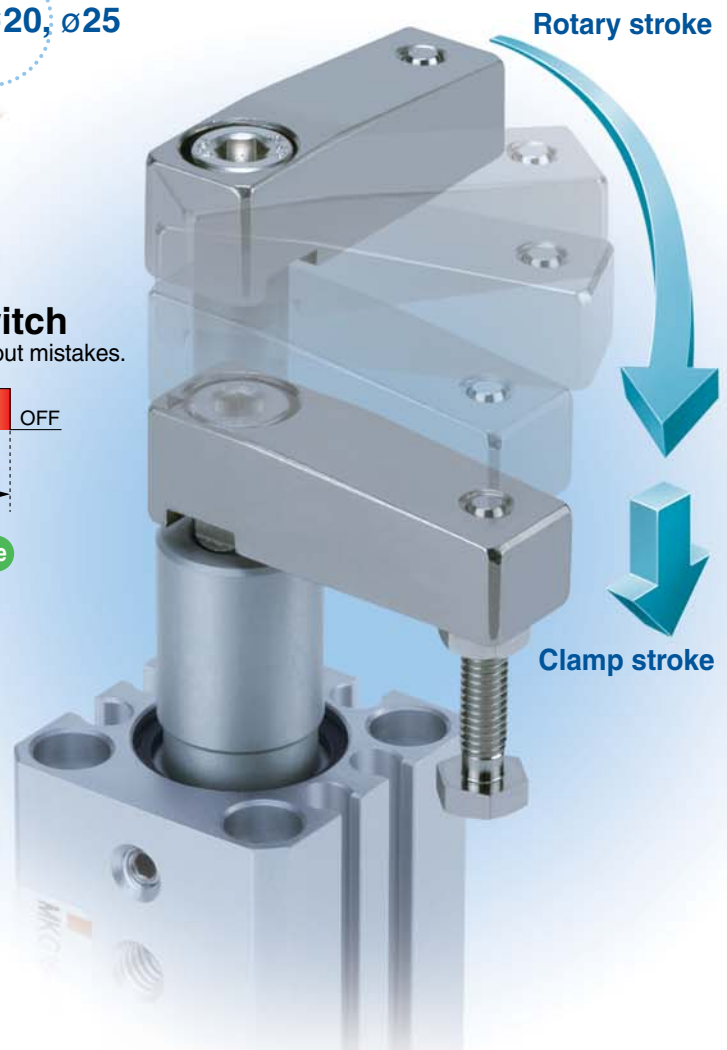
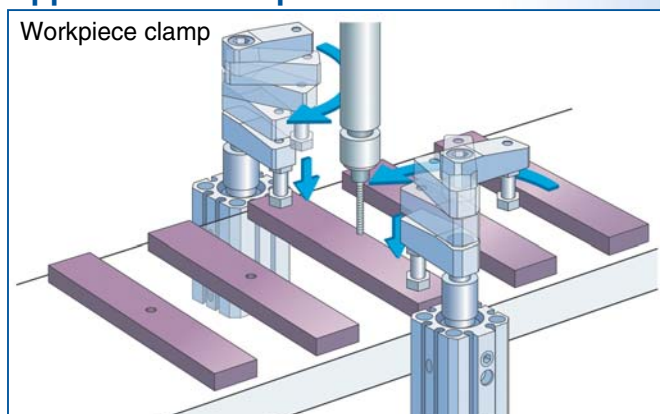

Series MK



CAT.ES20-214A

Allowable moment of inertia 3 times higher

Allowable moment of inertia is the same as the heavy-duty MK2 series.

Allowable Moment of Inertia (ø32, ø40)

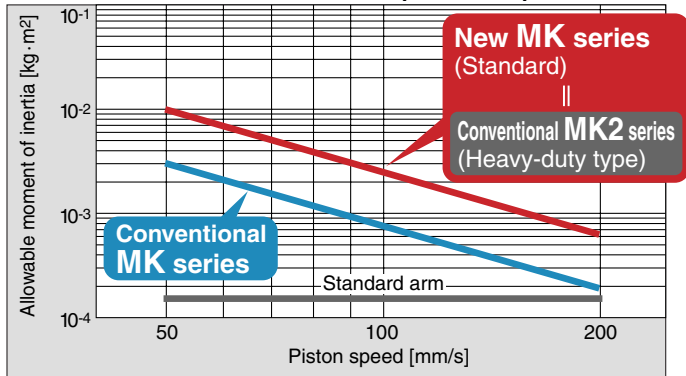

Maintenance can be performed for all sizes.

Seal kit and guide pin are replaceable.

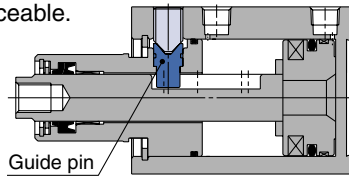

Magnetic field resistant auto switch can be used.

Applicable to the D-P3DW type

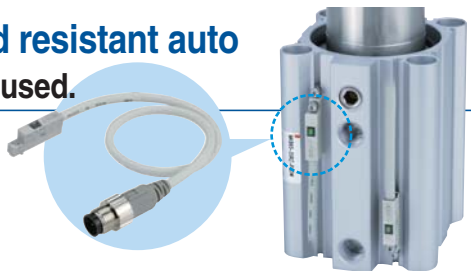

Standard stroke range has been expanded.

Strokes have been added to the New MK series, making a wide range of strokes available. (★ indicates the added strokes.)

Series	Bore size	Stroke			
		10	20	30	50
NEW MK	12	●	●	★	—
	16	●	●	★	—
	20	●	●	★	—
	25	●	●	★	—
	32	●	●	★	★
	40	●	●	★	★
	50	★	●	★	●
63	★	●	★	●	

Head flanges are newly available for ø12 and ø16.

Mounting type has been added to suit a wide range of applications.



Overall length is shortened.
(equivalent to the MK series)

3 to 10 mm shorter than the MK2 series, making the product more compact.

Overall length comparison



Overall Length Dimensions

Bore size	Shortened dimensions (compared to the conventional MK2 series)	NEW MK series overall length (at 20st)
20	3 mm	112.5
25	5 mm	113.5
32	8 mm	133.5
40	8 mm	134.5
50	10 mm	152
63	10 mm	155

2 types of cylinder mounting are available with one body.

2 types of cylinder mounting, **through-hole mounting** and **tap mounting**, are available for mounting the cylinder.
* For the tap mounting, the thread length is different from the existing product.

Mounting examples

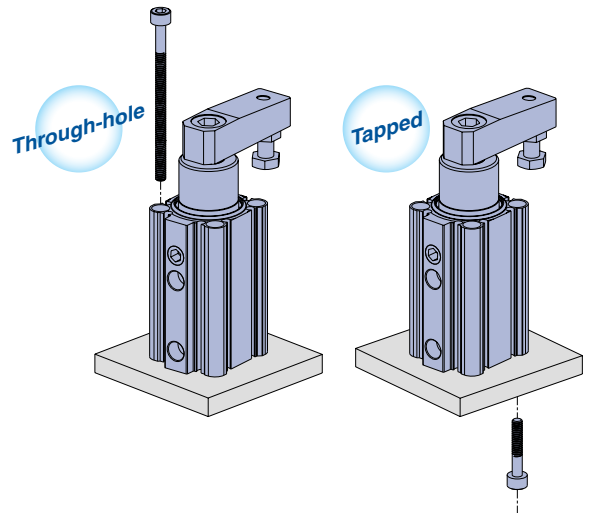

Clamping rotary direction can be selected from 2 types.

Clamping rotary direction can be selected to suit the setting conditions.

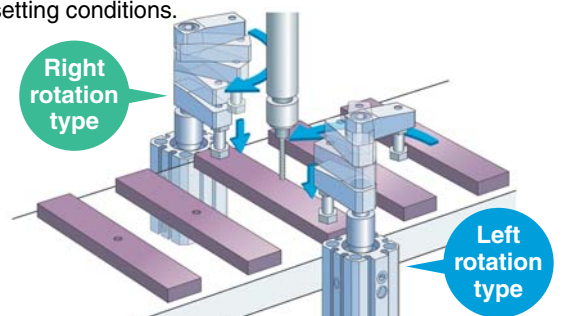

Series MK Model Selection

Item	Series	New MK
Max. piston speed ^{Note)} [mm/s]	ø12 to ø63	200
Non-rotating accuracy (Clamp part)	ø12	±1.4°
	ø16 to ø25	±1.2°
	ø32, ø40	±0.9°
	ø50, ø63	±0.7°
Rotary angle		90°±10°
Horizontal mounting		Not allowed

Note) Maximum piston speed indicates the maximum speed possible when employing a standard arm.

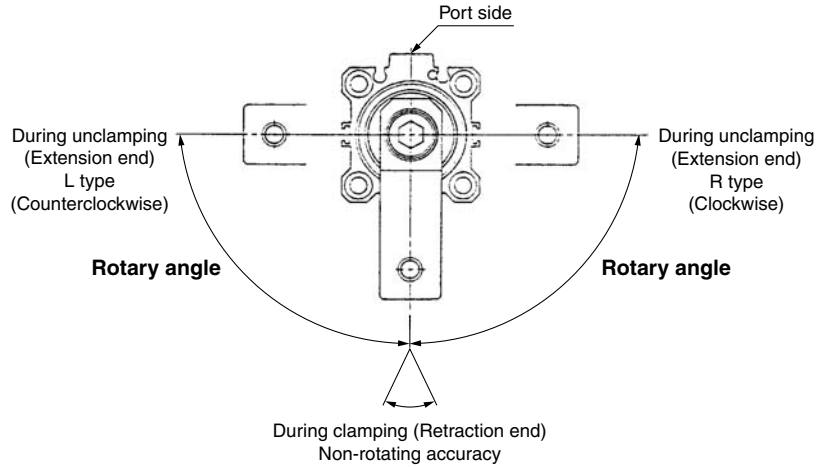

Designing Arms

⚠ Caution

When arms are to be made separately, their length and mass should be within the following range.

1. Allowable bending moment

Use the arm length and operating pressure within **Graph (1)** for allowable bending moment loaded piston rod.

Graph (1)

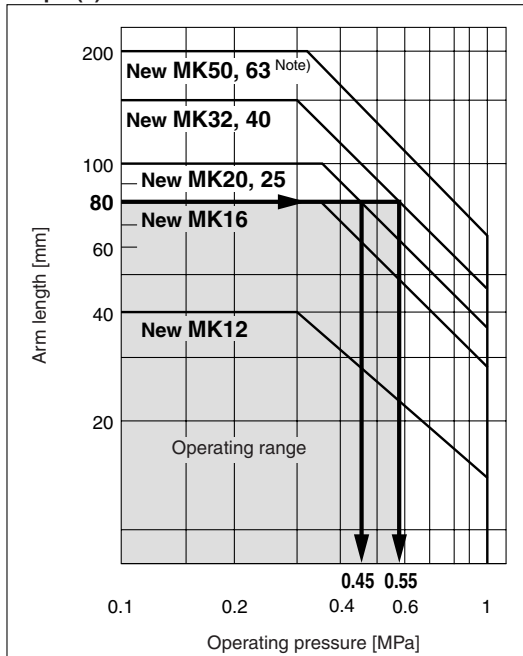

- When the arm length is 80 mm, pressure should be
New MK20/25: 0.45 MPa or less,
New MK32/40: 0.55 MPa or less.

Note) Use ø63 within a pressure range from 0.1 to 0.6 MPa. If ø63 is used within a pressure range from 0.61 to 1 MPa, please use -X2071.

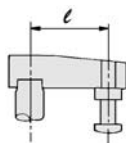

2. Moment of inertia

When the arm is long and heavy, damage of internal parts may be caused due to inertia. Use the moment of inertia and cylinder speed within **Graph (2)** based on arm requirements.

Graph (2)

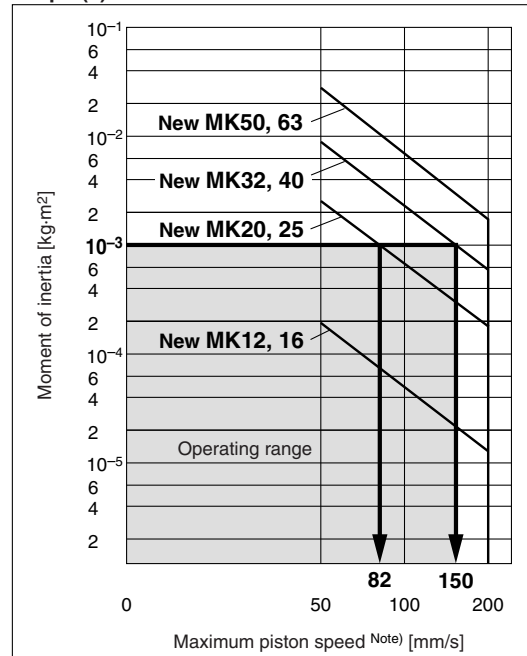

- When the arm's moment of inertia is 1 x 10⁻³ kg·m², cylinder speed should be
New MK20/25: 82 mm/s or less,
New MK32/40: 150 mm/s or less.

Note) Maximum piston speed is equivalent to approximately 1.6x the average piston speed. (Rough indication)

Bore Size Selection

Moment of Inertia

Note) Maximum piston speed is equivalent to approximately 1.6x the average piston speed. (Rough indication)

Calculate the operating conditions and operate this product within the allowable range.

If the allowable range is exceeded, increase the bore size or use the MK2T series.

(Refer to SMC Best Pneumatics No. 3 for details of the MK2T series.)

ø12, ø16

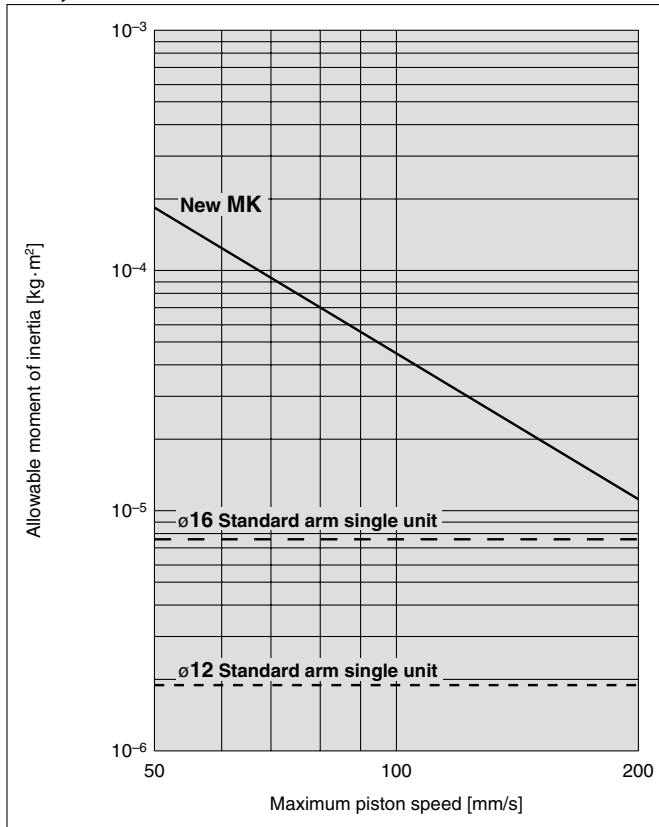

ø20, ø25

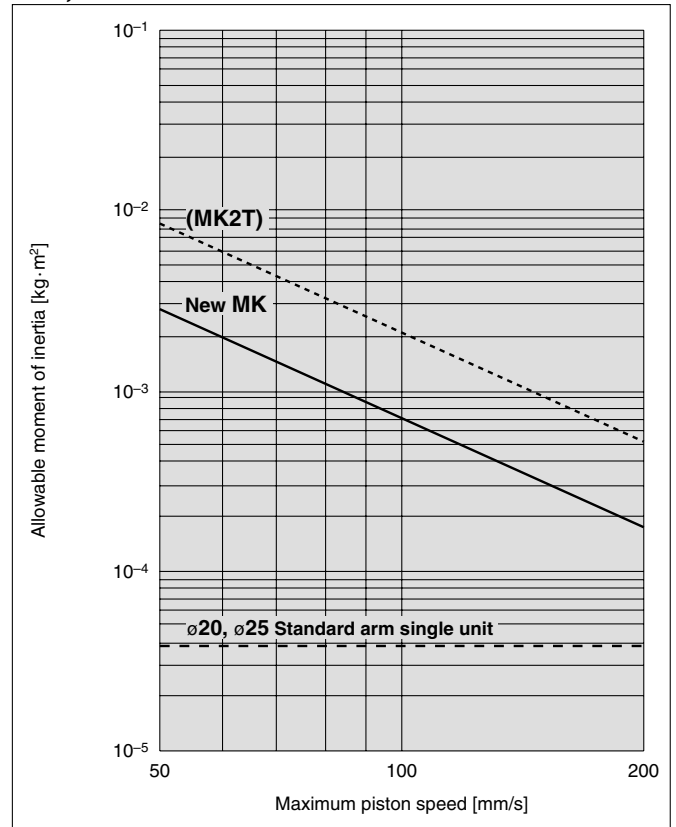

ø32, ø40

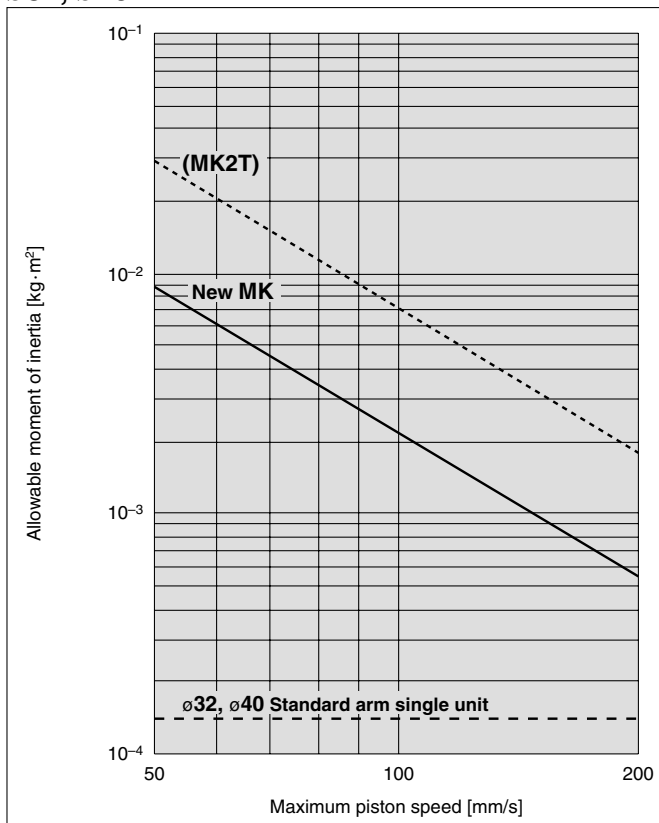

ø50, ø63

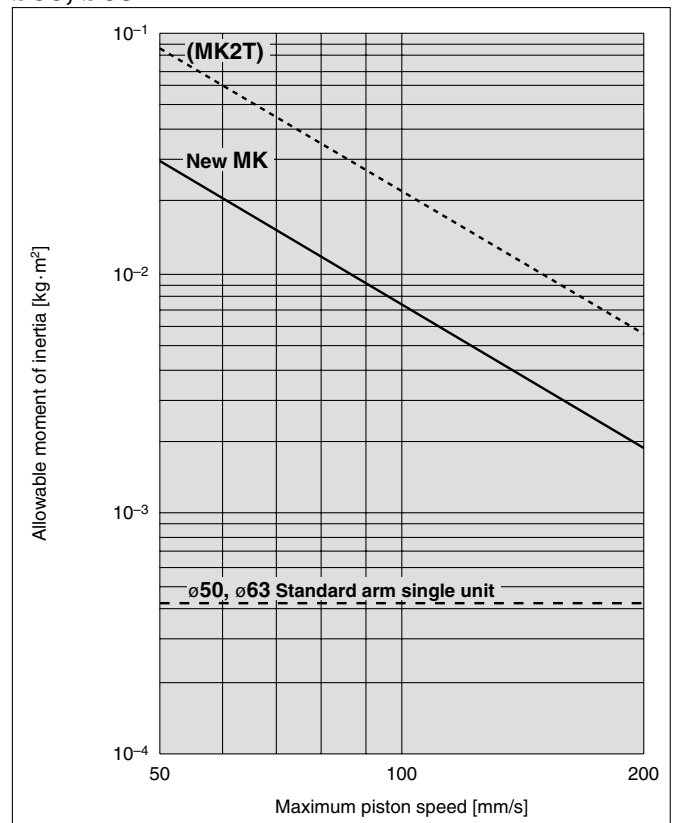

Moment of Inertia

Note) Maximum piston speed is equivalent to approximately 1.6x the average piston speed. (Rough indication)

Calculation example when arms other than the options are used.

- Calculate the moment of inertia of the arm.

$$I_1 = m_1 \cdot \frac{A^2 + B^2}{12} + m_1 \cdot \left(\frac{A}{2} - S \right)^2$$

- Calculate the moment of inertia of the clamping jig.

$$I_2 = m_2 \cdot \frac{D^2}{8} + m_2 \cdot L^2$$

<Calculation example> when the cylinder bore size is $\phi 32$.

A = 0.1 m	D = 0.02 m
B = 0.03 m	m ₁ = 0.35 kg
S = 0.012 m	m ₂ = 0.15 kg
L = 0.076 m	

$$I_1 = 0.35 \times \frac{0.1^2 + 0.03^2}{12} + 0.35 \times \left(\frac{0.1}{2} - 0.012 \right)^2 = 8.2 \times 10^{-4} \text{ kg}\cdot\text{m}^2$$

$$I_2 = 0.15 \times \frac{0.02^2}{8} + 0.15 \times 0.076^2 = 8.7 \times 10^{-4} \text{ kg}\cdot\text{m}^2$$

- Calculate the actual moment of inertia.

$$I = I_1 + I_2 = (8.2 + 8.7) \times 10^{-4} = 1.7 \times 10^{-3} \text{ kg}\cdot\text{m}^2$$

Calculation result (when the bore size is $\phi 32$ and clamp stroke is 10 mm.)

Model	Max. piston speed	Average piston speed <small>Note 1)</small>	Total stroke <small>Note 2)</small>	Stroke time <small>Note 3)</small>
New MK	115 mm/s	72 mm/s	25 mm	0.35 seconds

Note 1) Average piston speed = Max. piston speed \div 1.6

Note 2) Total stroke = Clamp stroke + Rotary stroke

Note 3) Total stroke \div Average piston speed

The stroke time should be longer than the above mentioned stroke time.

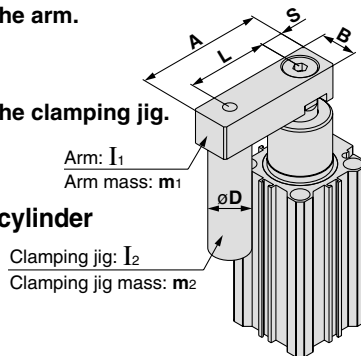

$\phi 32, \phi 40$

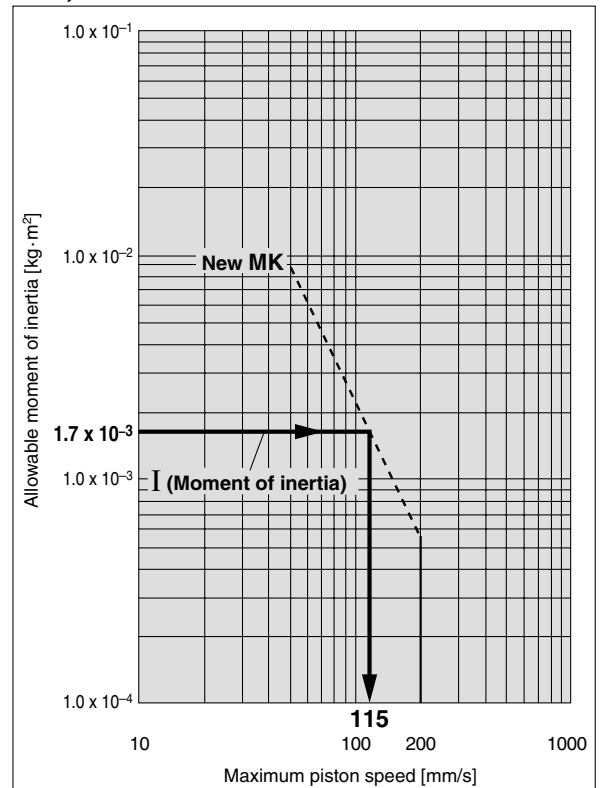

Calculation Equation List for Moment of Inertia

I: Moment of inertia [kg·m²] m: Load mass [kg]

If arms other than the options are used, be sure to calculate the moment of inertia of the arm before selecting it.

1. Thin shaft

Position of rotational axis:
Perpendicular to the shaft, and attached near one end

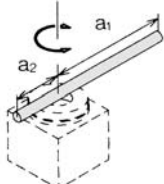

$$I = m_1 \cdot \frac{a_1^2}{3} + m_2 \cdot \frac{a_2^2}{3}$$

2. Thin shaft

Position of rotational axis:
Perpendicular to the shaft, and attached at the center of gravity

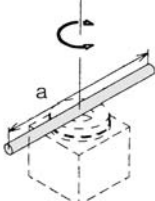

$$I = m \cdot \frac{a^2}{12}$$

3. Thin rectangular plate (Rectangular parallelepiped)

Position of rotational axis:
Parallel to side b, and attached at the center of gravity

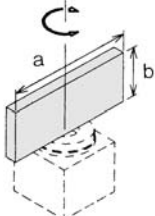

$$I = m \cdot \frac{a^2}{12}$$

4. Thin rectangular plate (Rectangular parallelepiped)

Position of rotational axis:
Perpendicular to the plate, and attached near one end

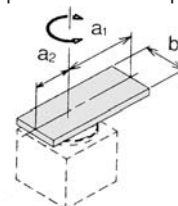

$$I = m_1 \cdot \frac{4a_1^2 + b^2}{12} + m_2 \cdot \frac{4a_2^2 + b^2}{12}$$

5. Thin rectangular plate (Rectangular parallelepiped)

Position of rotational axis:
Attached at the center of gravity, and perpendicular to the plate
(Same as also thick rectangular plate)

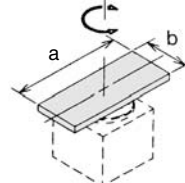

$$I = m \cdot \frac{a^2 + b^2}{12}$$

6. Load at the end of lever arm

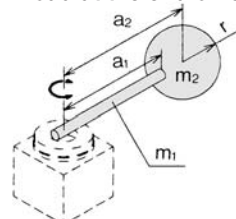

$$I = m_1 \cdot \frac{a_1^2}{3} + m_2 \cdot a_2^2 + k$$

$$k = m_2 \cdot \frac{2r^2}{5}$$

Bore Size Selection

Design/Selection

⚠ Caution

1. Do not use the cylinder under the following environments:

- An area in which fluids such as cutting oil splash on the piston rod
- An area in which foreign matter such as particles, cutting chips, or dust is present
- An area in which the ambient temperature exceeds the operating range
- An area exposed to direct sunlight
- An environment that poses the risk of corrosion

2. A cylinder could malfunction or the non-rotating accuracy could be affected if a rotational force is applied to the piston rod. Therefore, observe the particulars given below before operating the cylinder.

- 1) Make sure to mount the cylinder vertically (**Fig. (1)**).
- 2) Do not absolutely perform any work (such as clamping or acting as a stopper, etc.) in the rotary direction (**Fig. (2)**).
- 3) To clamp, make sure to do so within the clamp stroke (straight-line stroke) (**Fig. (3)**).
- 4) Make sure that the clamping surface of the workpiece is perpendicular to the cylinder's axial line (**Fig. (4)**).
- 5) Do not operate the cylinder in such a way that an external force causes the workpiece to move while being clamped (**Fig. (5)**).
- 6) Furthermore, do not operate the cylinder in an application in which a rotational force will be applied to the piston rod.

- 1) Do not operate the cylinder horizontally.
When using the cylinder horizontally, use the MK2T series.

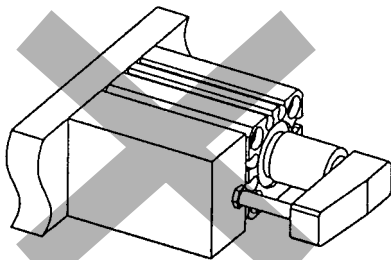

Fig. (1)

- 2) Do not perform any work in the rotary direction.

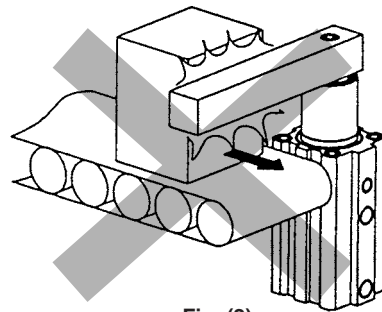

Fig. (2)

- 3) Do not clamp during the rotary stroke. Clamp should be performed within the clamp stroke.

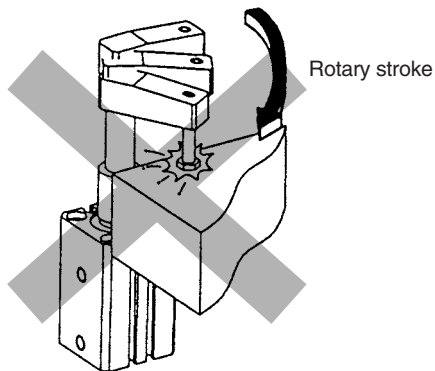
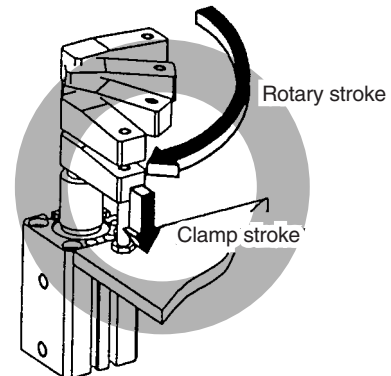

Fig. (3)



- 4) Do not clamp on a slanted surface.

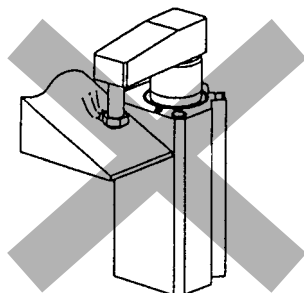

Fig. (4)

- 5) Make sure that the workpiece does not move during clamping.

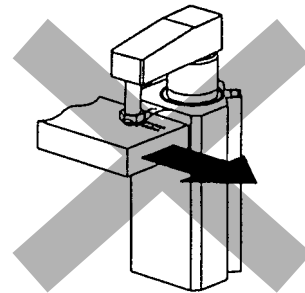

Fig. (5)

Rotary Clamp Cylinder: Standard

Series MK

ø12, ø16, ø20, ø25, ø32, ø40, ø50, ø63

How to Order

Rotary clamp cylinder •

Mounting bracket •

Symbol	Mounting
B	Through-hole/Both ends tapped common (Basic)
G	Head flange

* Head flanges are shipped together, (but not assembled).

Bore size •

12	12 mm
16	16 mm
20	20 mm
25	25 mm
32	32 mm
40	40 mm
50	50 mm
63	63 mm

Port thread type •

Nil	M thread	ø12 to ø25
	Rc	
TN	NPT	ø32 to ø63
TF	G	

Clamp stroke •

Symbol	Clamp stroke	Applicable bore size
10	10 mm	ø12 to ø63
20	20 mm	
30	30 mm	
50	50 mm	ø32 to ø63

Auto switch type

Nil	2 pcs.
S	1 pc.

Auto switch type

Nil	Without auto switch (Built-in magnet)
------------	---------------------------------------

* For applicable auto switch models, refer to the below table.
* Auto switches are shipped together, (but not assembled).

Auto switch multiple side mounting

Body option

Nil	Standard (Female thread)
N	With arm

* Arms are shipped together, (but not assembled).

Rotary direction (Unclamp → Clamp)

R	Clockwise
L	Counterclockwise

During unclamping (Extension end) L type (Counterclockwise) During unclamping (Extension end) R type (Clockwise)

During clamping (Retraction end)

Applicable Auto Switches/Refer to Best Pneumatics No. 3 for further information on auto switches. For D-P3DW, refer to the catalog ES20-201.

Type	Special function	Electrical entry	Indicator light	Wiring (Output)	Load voltage		Auto switch model		Lead wire length (m)					Pre-wired connector	Applicable load		
					DC	AC	Perpendicular	In-line	0.5 (Nil)	1 (M)	3 (L)	5 (Z)	None (N)				
Solid state switch	—	Grommet	Yes	3-wire (NPN)	24 V	5 V, 12 V	—	M9NV	M9N	●	●	●	○	—	○	IC circuit	Relay, PLC
				3-wire (PNP)				M9PV	M9P	●	●	●	○	—	○		
				2-wire				M9BV	M9B	●	●	●	○	—	○		
				3-wire (NPN)				M9NWV	M9NW	●	●	●	○	—	○		
	3-wire (PNP)			M9PWV				M9PW	●	●	●	○	—	○	IC circuit		
	2-wire			M9BWV				M9BW	●	●	●	○	—	○			
	3-wire (NPN)			M9NAV**				M9NA**	○	○	●	○	—	○	IC circuit		
	3-wire (PNP)			M9PAV**				M9PA**	○	○	●	○	—	○			
	2-wire			M9BAV**				M9BA**	○	○	●	○	—	○	—		
	2-wire (Non-polar)			—				P3DW*	●	—	●	—	—	●			
Reed switch	—	Grommet	Yes	3-wire (NPN equivalent)	24 V	5 V, 12 V	100 V	A96V	A96	●	—	●	—	—	—	IC circuit	Relay, PLC
				2-wire				A93V	A93	●	—	●	—	—	—	—	
								A90V	A90	●	—	●	—	—	—	—	

** Water resistant type auto switches can be mounted on the above models, but in such case SMC cannot guarantee water resistance. Consult with SMC regarding water resistant types with the above model numbers.

* Lead wire length symbols: 0.5 m Nil (Example) M9NW
1 m M (Example) M9NWM
3 m L (Example) M9NWL
5 m Z (Example) M9NWZ

* Solid state auto switches marked with "○" are produced upon receipt of order.
* For D-P3DW□, ø32 to ø63 are available.

* Since there are other applicable auto switches than listed, refer to page 15 for details.
* For details about auto switches with pre-wired connector, refer to Best Pneumatics No. 3. For D-P3DW□, refer to the catalog ES20-201.
* Auto switches are shipped together, (but not assembled).



Specifications

Bore size (mm)	12	16	20	25	32	40	50	63
Action	Double acting							
Rotary angle ^{Note 1)}	90° ±10°							
Rotary direction ^{Note 2)}	Clockwise, Counterclockwise							
Rotary stroke (mm)	7.5		9.5		15		19	
Clamp stroke (mm)	10, 20, 30				10, 20, 30, 50			
Theoretical clamp force (N) ^{Note 3)}	40	75	100	185	300	525	825	1400
Fluid	Air							
Proof pressure	1.5 MPa							
Operating pressure range	0.1 to 1 MPa							^{Note 4)} 0.1 to 0.6 MPa
Ambient and fluid temperature	Without auto switch: -10 to 70°C (No freezing) With auto switch: -10 to 60°C (No freezing)							
Lubrication	Non-lube							
Piping port size	M5 x 0.8			Rc1/8, NPT1/8 G1/8		Rc1/4, NPT1/4 G1/4		
Mounting	Through-hole/Both ends tapped common, Head flange							
Cushion	Rubber bumper							
Stroke length tolerance	+0.6 -0.4							
Piston speed ^{Note 5)}	50 to 200 mm/s							
Non-rotating accuracy (Clamp part) ^{Note 1)}	±1.4°		±1.2°		±0.9°		±0.7°	

Note 1) Refer to Rotary Angle figure.

Note 2) Direction of rotation viewed from the rod end when the piston rod is retracting

Note 3) Clamp force at 0.5 MPa

Note 4) When using the cylinder within a pressure range from 0.61 to 1 MPa, please use -X2071.

Note 5) Be sure to install a speed controller to the cylinder, and adjust the cylinder speed to make it within the range from 50 to 200 mm/s. To adjust the speed, start with the needle in the completely closed position, and then adjust it by opening gradually.

Rotary Angle

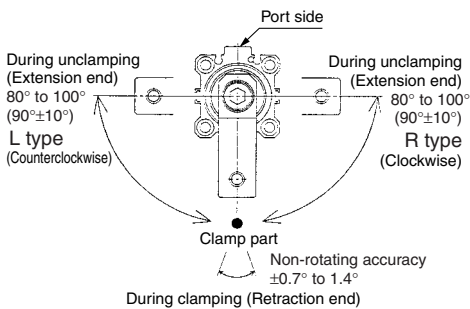

Theoretical Output

Unit: N

Bore size (mm)	Rod size (mm)	Operating direction	Piston area (cm ²)	Operating pressure (MPa)			
				0.3	0.5	0.7	1.0
12	6	IN	0.8	25	42	59	85
		OUT	1.1	34	57	79	113
16	8	IN	1.5	45	75	106	151
		OUT	2.0	60	101	141	201
20	12	IN	2.0	60	101	141	201
		OUT	3.1	94	157	220	314
25	12	IN	3.8	113	189	264	378
		OUT	4.9	147	245	344	491
32	16	IN	6.0	181	302	422	603
		OUT	8.0	241	402	563	804
40	16	IN	10.6	317	528	739	1056
		OUT	12.6	377	628	880	1257
50	20	IN	16.5	495	825	1155	1649
		OUT	19.6	589	982	1374	1963
63	20	IN	28.0	841	1402	—	—
		OUT	31.2	935	1559	—	—

Note) Theoretical output (N) = Pressure (MPa) x Piston area (cm²) x 100
Operating direction IN: Clamp OUT: Unclamp



Made to Order

(For details, refer to page 17.)

Symbol	Description
-X2071	Max. operating pressure 1.0 MPa
-X2094	Overall length is the same as the MK2 series

Option/Arm

Bore size (mm)	Part no.	Accessories
12	MK-A012Z	Clamp bolt, Hexagon socket head cap screw, Hexagon nut, Spring washer
16	MK-A016Z	
20	MK-A020Z	
25		
32	MK-A032Z	
40	MK-A050Z	
50		
63		

Mounting Bracket/Flange

Bore size (mm)	Part no.	Accessories
12	CQS-F012	Hexagon socket head cap screw
16	CQS-F016	
20	MKZ-F020	
25	MKZ-F025	
32	MK2T-F032	
40	MK2T-F040	
50	MK2T-F050	
63	MK2T-F063	

Weight

Unit: g

Clamp stroke (mm)	Bore size (mm)							
	12	16	20	25	32	40	50	63
10	69	94	222	282	445	517	921	1256
20	84	113	250	319	494	570	1001	1364
30	99	132	279	355	542	623	1081	1472
50	—	—	—	—	639	728	1241	1687

Additional Weight

Unit: g

Bore size (mm)	12	16	20	25	32	40	50	63
With arm	13	32	100	100	200	200	350	350
Head flange (including mounting bolt)	58	69	130	150	175	209	371	578

Calculation: (Example) MKG20-10RNZ • Standard calculation: MKB20-10RZ222 g
• Extra weight calculation: Head flange130 g
With arm100 g
452 g

Mounting Bolt for MKB-Z

Mounting: Mounting bolt for through-hole type is available.
Refer to the following for ordering procedures.
Order the actual number of bolts that will be used.

Example) CQ-M3x50L 4 pcs.

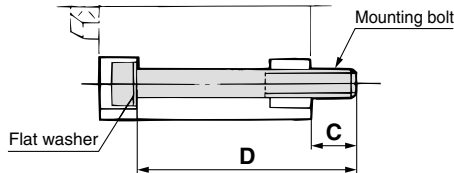

Note) Be sure to use a flat washer to mount cylinders via through-holes.

Cylinder model	C	D	Mounting bolt part no.
MKB12-10□Z	8	50	CQ-M3 x 50L
-20□Z		60	x 60L
-30□Z		70	x 70L
MKB16-10□Z	8	50	CQ-M3 x 50L
-20□Z		60	x 60L
-30□Z		70	x 70L
MKB20-10□Z	9	75	CQ-M5 x 75L
-20□Z		85	x 85L
-30□Z		95	x 95L
MKB25-10□Z	8	75	CQ-M5 x 75L
-20□Z		85	x 85L
-30□Z		95	x 95L
MKB32-10□Z	9.5	85	CQ-M5 x 85L
-20□Z		95	x 95L
-30□Z		105	x 105L
-50□Z		125	x 125L
MKB40-10□Z	11	80	CQ-M5 x 80L
-20□Z		90	x 90L
-30□Z		100	x 100L
-50□Z		120	x 120L
MKB50-10□Z	10.5	90	CQ-M6 x 90L
-20□Z		100	x 100L
-30□Z		110	x 110L
-50□Z		130	x 130L
MKB63-10□Z	14.1	95	CQ-M8 x 95L
-20□Z		105	x 105L
-30□Z		115	x 115L
-50□Z		135	x 135L

Clamp Arm Mounting

⚠ Caution

Use a clamp arm that is available as an option.

To fabricate a clamp arm, make sure that the allowable bending moment and the inertial moment will be within the specified range. Refer to Graph 1 and 2 on page 1.

Ensuring Safety

⚠ Caution

If one side of the piston is pressurized by supplying air with the clamp arm attached, the piston will move vertically while the clamp arm rotates.

This operation could be hazardous to personnel, as their hands or feet could get caught by the clamp arm, or could lead to equipment damage. Therefore, it is important to secure as a danger zone a cylindrical area with the length of the clamp arm as its radius, and the stroke plus 20 mm as its height.

Clamp Arm Mounting and Removal

⚠ Caution

When the arm is mounted onto or removed from the piston rod, do not fix the cylinder body, but hold the arm with a spanner when tightening or loosening the bolt (Fig. 1).

If the bolt is tightened with the cylinder body fixed, excessive rotation force will be applied to the piston rod, which may damage the internal components.

Note that when making an arm, machine it so that it engages with the width across flats on the rod end to prevent it from rotating.

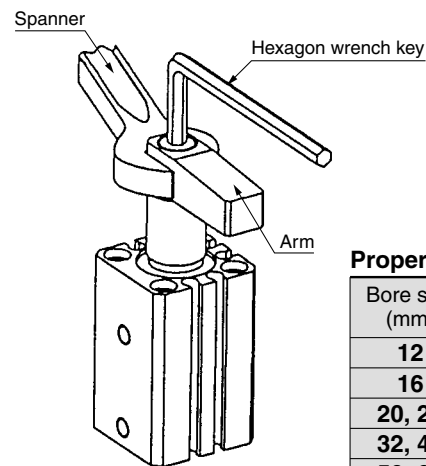

Fig. 1

Proper Tightening Torque

Bore size (mm)	Proper tightening torque (N·m)
12	0.5 to 0.7
16	2.8 to 3.5
20, 25	11.5 to 14.0
32, 40	24 to 30
50, 63	75 to 90

Head Flange Mounting

⚠ Caution

The mounting bolt for the head flange should be tightened to the torque shown in the below table.

Bore size	Thread size	Tightening torque
ø12, 16	M4 x 0.7	1.4 to 2.6 N·m
ø20 to 40	M6 x 1.0	9.0 to 12.0 N·m
ø50	M8 x 1.25	11.4 to 22.4 N·m
ø63	M10 x 1.5	25.0 to 44.9 N·m

Series MK

Construction

New MK12, 16

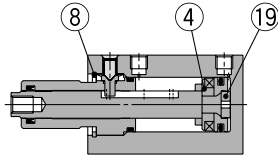

New MK20 to 32

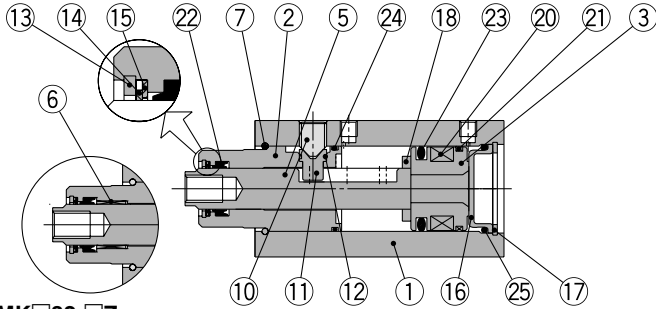

MK□32-□Z

With arm (N)

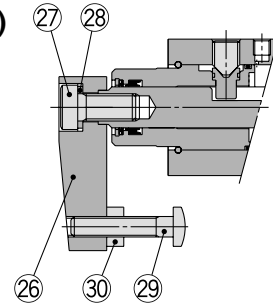

New MK40 to 63

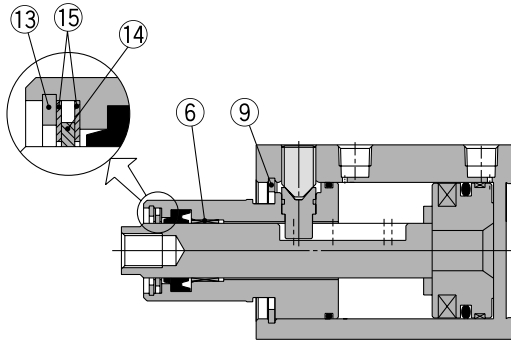

Head flange (G)

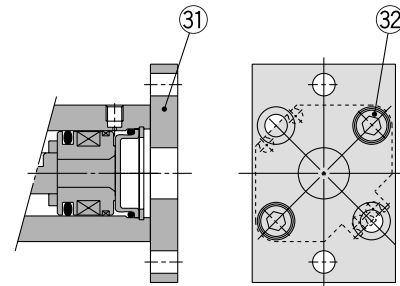

Component Parts

No.	Description	Material	Note
1	Cylinder tube	Aluminum alloy	Hard anodized
2	Rod cover	Aluminum alloy	Hard anodized
3	Piston	Aluminum alloy	Chromated
4	Magnet holder	Aluminum alloy	Chromated
5	Piston rod	Stainless steel	ø12 to ø25 Nitriding
		Carbon steel	ø32 to ø63 Heated, Nickel plated
6	Bushing	Copper bearing material	ø32 to ø63 only
7	Stop ring	Stainless steel	ø20 to ø32 only
8	Round R-type retaining ring	Carbon tool steel	ø12, ø16 only
9	C-type retaining ring	Carbon tool steel	ø40 to ø63 only
10	Hexagon socket head set screw	Chromium molybdenum steel	Sharp end section: 90°
11	Guide pin	Stainless steel	Nitriding
12	O-ring	NBR	
13	Round R-type retaining ring	Carbon tool steel	Except ø12, ø16
14	Coil scraper	Phosphor bronze	Except ø12, ø16
15	Scraper pressure	Stainless steel	Except ø12, ø16
16	Head cover	Rolled steel	Electroless nickel plated
17	C-type retaining ring	Carbon tool steel	ø20 to ø32 only

Component Parts

No.	Description	Material	Note
18	Bumper	Urethane	
19	Bumper B	Urethane	ø12, ø16 only
20	Magnet	—	
21	Wear ring	Resin	Except ø12, ø16
22	Rod seal	NBR	
23	Piston seal	NBR	
24	Gasket	NBR	
25	O-ring	NBR	ø20 to ø32 only
26	Arm	Rolled steel	
27	Hexagon socket head cap screw	Chromium molybdenum steel	
28	Spring washer	Hard steel	
29	Clamp bolt	Chromium molybdenum steel	
30	Hexagon nut	Rolled steel	
31	Flange	Rolled steel	
32	Hexagon socket head cap screw	Chromium molybdenum steel	Qty. ø12, ø16, ø32 to ø40: 4 pcs. ø20, ø25: 2 pcs.

Replacement Parts/Seal Kit

Bore size (mm)	ø12	ø16	ø20	ø25	ø32	ø40	ø50	ø63
Kit no.	CQSB12-PS	CQSB16-PS	MK20Z-PS	MK25Z-PS	MK32Z-PS	MK2T40-PS	MK2T50-PS	MK63Z-PS
Contents	Set of nos. above 22 23 24			Set of nos. above 14 22 23 24				

* Seal kit includes numbers in the table. Order the seal kit, based on each bore size.

* Since the seal kit does not include a grease pack, order it separately. **Grease pack part no.: GR-S-010** (10 g)

Replacement Parts/Guide Pin Kit

Bore size (mm)	ø12	ø16	ø20	ø25	ø32	ø40	ø50	ø63
Kit no.	MK12Z-GS	MK16Z-GS	MK20Z-GS	MK25Z-GS	MK32Z-GS	MK40Z-GS	MK50Z-GS	MK63Z-GS
Contents	Set of nos. above 10 11 12							

* Guide pin kit includes numbers in the table. Order the guide pin kit, based on each bore size.

* For the replacement procedure of the replacement parts/seal and guide pin kits, refer to the Operation Manual.

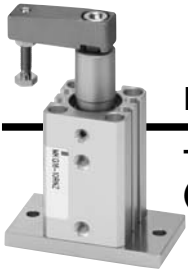

Dimensions: $\varnothing 12, \varnothing 16$

The outline dimensions shown are when the rod is retracted.

Through-hole/Both ends tapped common (Basic)

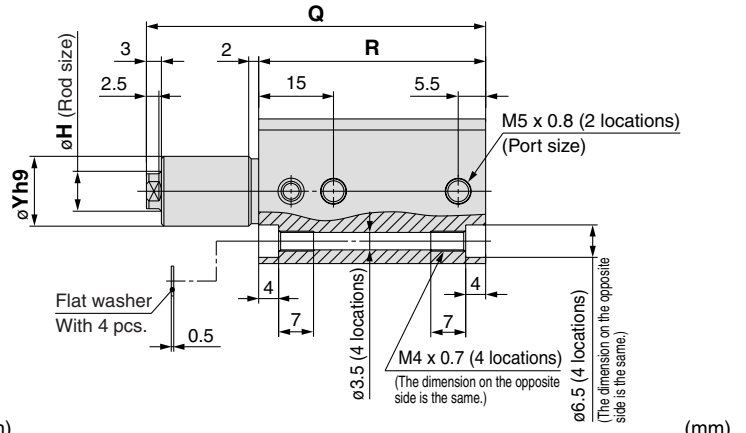
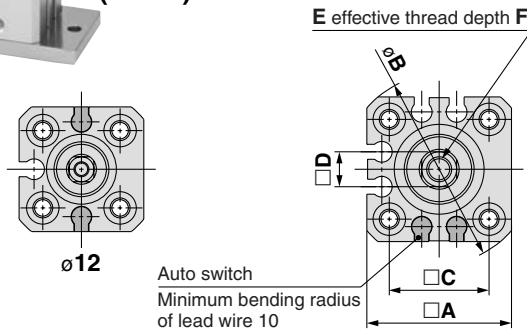

Basic (mm)

Model	A	B	C	D	E	F	H	$\varnothing Yh9$
MKB12-Z	25	32	15.5	5	M3 x 0.5	5.5	6	11 $^{0}_{-0.043}$
MKB16-Z	29	38	20	7	M5 x 0.8	6.5	8	14 $^{0}_{-0.043}$

Model	Rod state	Clamp stroke					
		10 mm		20 mm		30 mm	
		Q	R	Q	R	Q	R
MKB12-Z	Retracted	68	45.5	88	55.5	108	65.5
	Extended	85.5		115.5		145.5	
MKB16-Z	Retracted	68	45.5	88	55.5	108	65.5
	Extended	85.5		115.5		145.5	

Note) The above figure is with the auto switch (D-M9□) mounted.

With arm

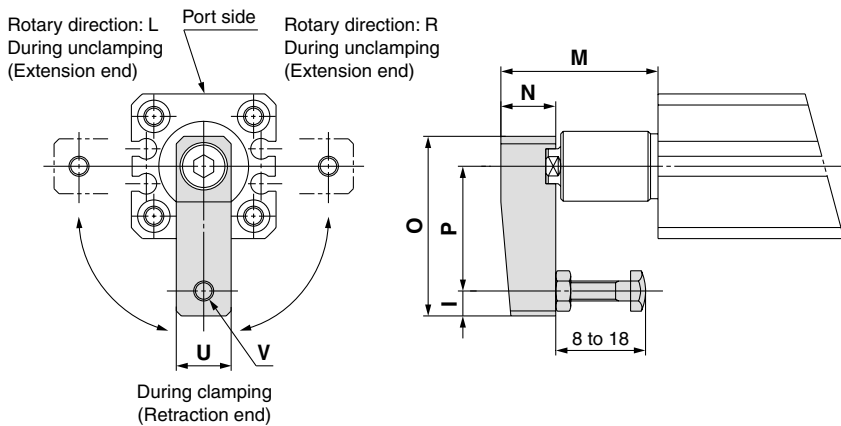

With Arm (mm)

Model	I	N	O	P	U	V
MKB12-Z	4	8	29	20	8	M3 x 0.5
MKB16-Z	5	11	36	25	11	M4 x 0.7

Model	Rod state	M		
		Clamp stroke		
		10 mm	20 mm	30 mm
MKB12-Z	Retracted	28.5	38.5	48.5
	Extended	46	66	86
MKB16-Z	Retracted	31.5	41.5	51.5
	Extended	49	69	89

Head flange

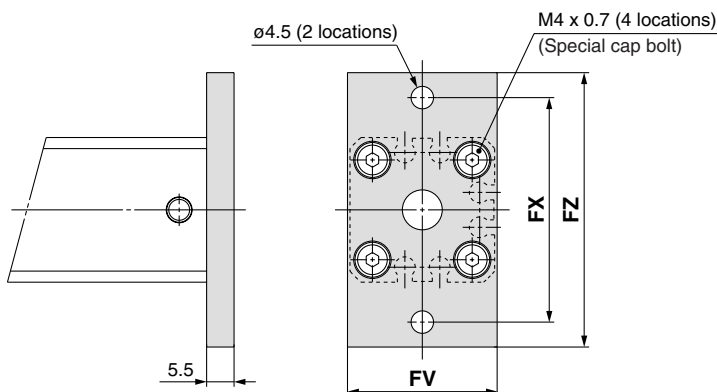

Head Flange (mm)

Model	FV	FX	FZ
MKG12-Z	25	45	55
MKG16-Z	30	45	55

Series MK

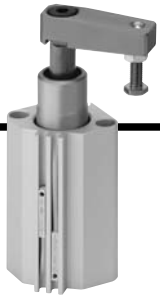

Dimensions: $\varnothing 20$, $\varnothing 25$

The outline dimensions shown are when the rod is retracted.

Through-hole/Both ends tapped common (Basic)

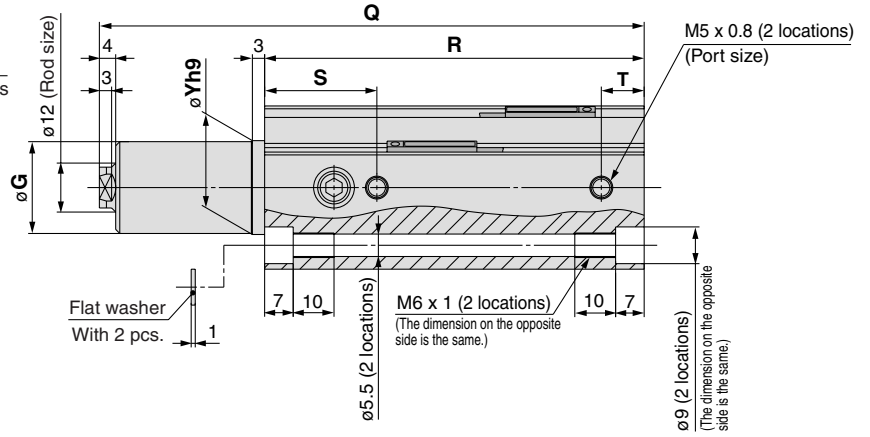
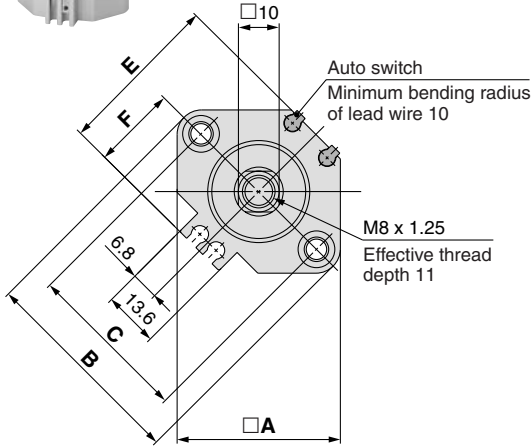

Basic (mm)									
Model	A	B	C	E	F	G	$\varnothing Yh9$	S	T
MKB20-Z	36	47	36	35.5	18	17.9	18 ⁰ _{-0.043}	28	9
MKB25-Z	40	52	40	40.5	21	22.5	23 ⁰ _{-0.052}	27.5	10.5

Model	Rod state	Clamp stroke (mm)					
		10 mm		20 mm		30 mm	
		Q	R	Q	R	Q	R
MKB20-Z	Retracted	92.5	72	112.5	82	132.5	92
	Extended	112		142		172	
MKB25-Z	Retracted	93.5	73	113.5	83	133.5	93
	Extended	113		143		173	

Note) The above figure is with the auto switch (D-M9□) mounted.

With arm

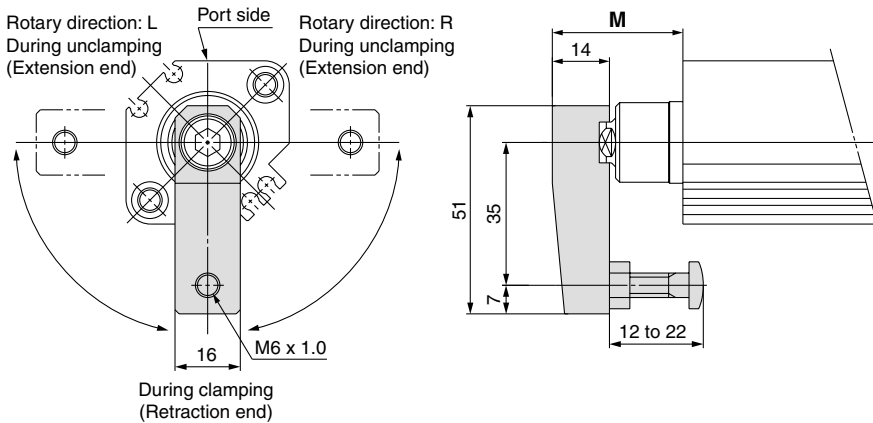

With Arm (mm)				
Model	Rod state	M		
		Clamp stroke		
		10 mm	20 mm	30 mm
MKB20-Z	Retracted	32	42	52
	Extended	51.5	71.5	91.5
MKB25-Z	Retracted	32	42	52
	Extended	51.5	71.5	91.5

Head flange

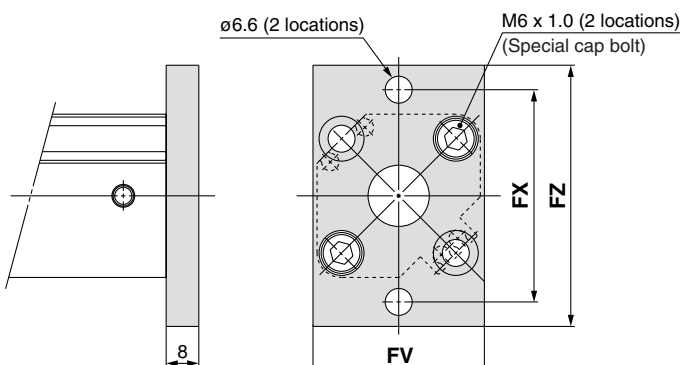

Head Flange (mm)			
Model	FV	FX	FZ
MKG20-Z	39	48	60
MKG25-Z	42	52	64



Dimensions: $\varnothing 32, \varnothing 40, \varnothing 50, \varnothing 63$

The outline dimensions shown are when the rod is retracted.

Through-hole/Both ends tapped common (Basic)

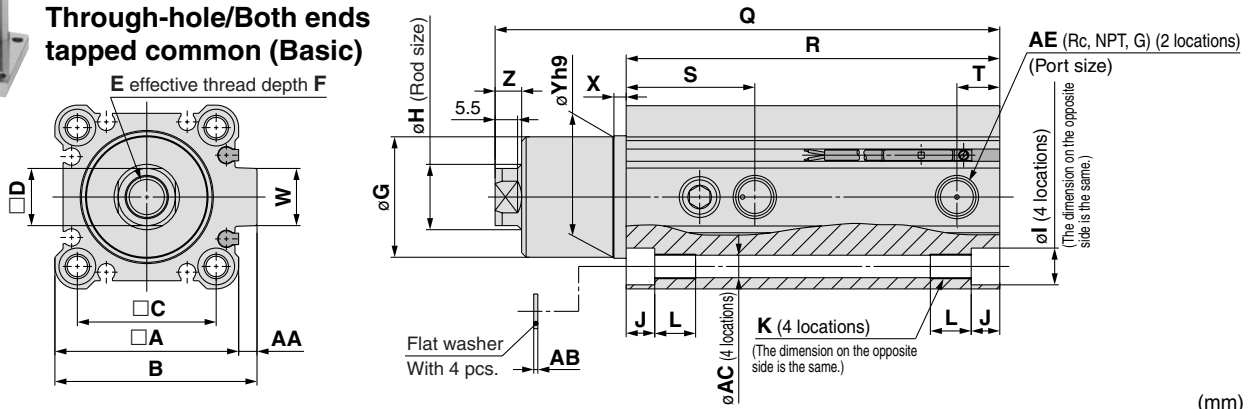

Basic

Model	A	B	C	D	E	F	G	H	I	J	K	L	S	T	W	X	$\varnothing Yh9$	Z	AA	AB	$\varnothing AC$	AE
MKB32-Z	45	49.5	34	14	M10 x 1.5	12	29.5	16	9	7	M6 x 1.0	10	31.5	10.5	14	3	$30_{-0.062}^0$	6.5	4.5	1	5.5	1/8
MKB40-Z	52	57	40	14	M10 x 1.5	12	29.5	16	9	7	M6 x 1.0	10	29	9	15	3	$30_{-0.062}^0$	6.5	5	1	5.5	1/8
MKB50-Z	64	71	50	17	M12 x 1.75	15	36.5	20	11	8	M8 x 1.25	14	34	11.5	19	3.5	$37_{-0.062}^0$	7.5	7	1	6.6	1/4
MKB63-Z	77	84	60	17	M12 x 1.75	15	47.5	20	14	10.5	M10 x 1.5	18	34.5	10.5	19	3.5	$48_{-0.062}^0$	7.5	7	1.4	9	1/4

Model	Rod state	Clamp stroke							
		10 mm		20 mm		30 mm		50 mm	
		Q	R	Q	R	Q	R	Q	R
MKB32-Z	Retracted	113.5	81.5	133.5	91.5	153.5	101.5	193.5	121.5
	Extended	138.5	81.5	168.5	91.5	198.5	101.5	258.5	121.5
MKB40-Z	Retracted	114.5	75	134.5	85	154.5	95	194.5	115
	Extended	139.5	75	169.5	85	199.5	95	259.5	115
MKB50-Z	Retracted	132	86.5	152	96.5	172	106.5	212	126.5
	Extended	161	86.5	191	96.5	221	106.5	281	126.5
MKB63-Z	Retracted	135	90	155	100	175	110	215	130
	Extended	164	90	194	100	224	110	284	130

Note) The above figure is with the auto switch (D-M9□) mounted.

With arm

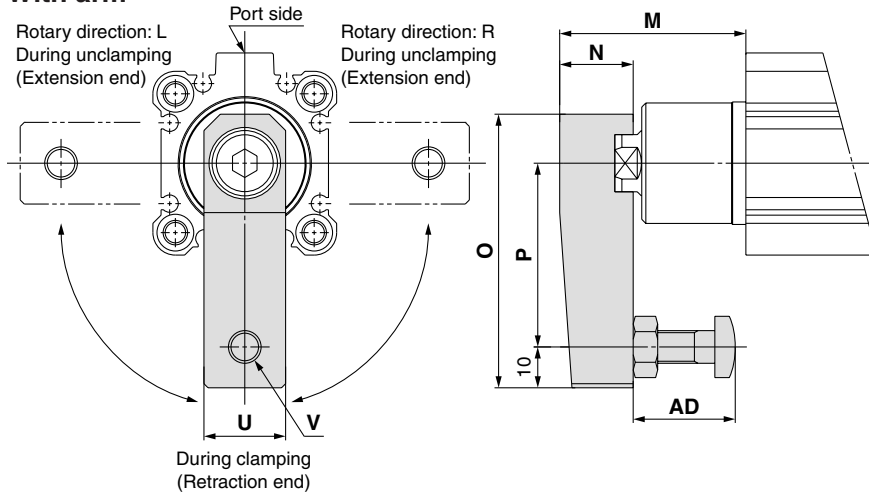

With Arm

Model	N	O	P	U	V	AD
MKB32-Z	18	67	45	20	M8 x 1.25	15 to 25
MKB40-Z	18	67	45	20	M8 x 1.25	15 to 25
MKB50-Z	22	88	65	22	M10 x 1.5	30 to 40
MKB63-Z	22	88	65	22	M10 x 1.5	30 to 40

Model	Rod state	M			
		Clamp stroke			
		10 mm	20 mm	30 mm	50 mm
MKB32-Z	Retracted	45.5	55.5	65.5	85.5
	Extended	70.5	90.5	110.5	150.5
MKB40-Z	Retracted	53	63	73	93
	Extended	78	98	118	158
MKB50-Z	Retracted	63	73	83	103
	Extended	92	112	132	172
MKB63-Z	Retracted	62.5	72.5	82.5	102.5
	Extended	91.5	111.5	131.5	171.5

Head flange

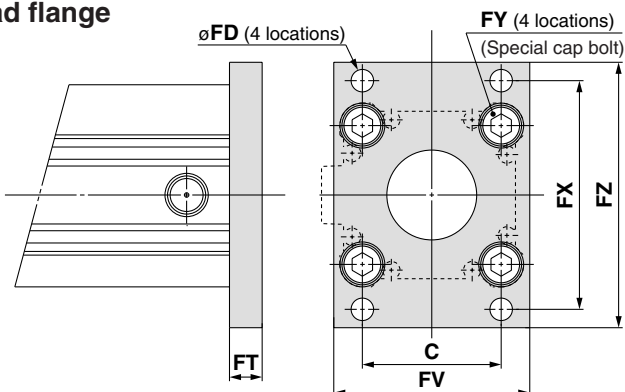

Head Flange

Model	C	$\varnothing FD$	FT	FV	FX	FY	FZ
MKB32-Z	34	5.5	8	48	56	M6 x 1.0	65
MKB40-Z	40	5.5	8	54	62	M6 x 1.0	72
MKB50-Z	50	6.6	9	67	76	M8 x 1.25	89
MKB63-Z	60	9	9	80	92	M10 x 1.5	108

Series MK

Auto Switch Proper Mounting Position (Detection at Stroke End) and its Mounting Height

ø12

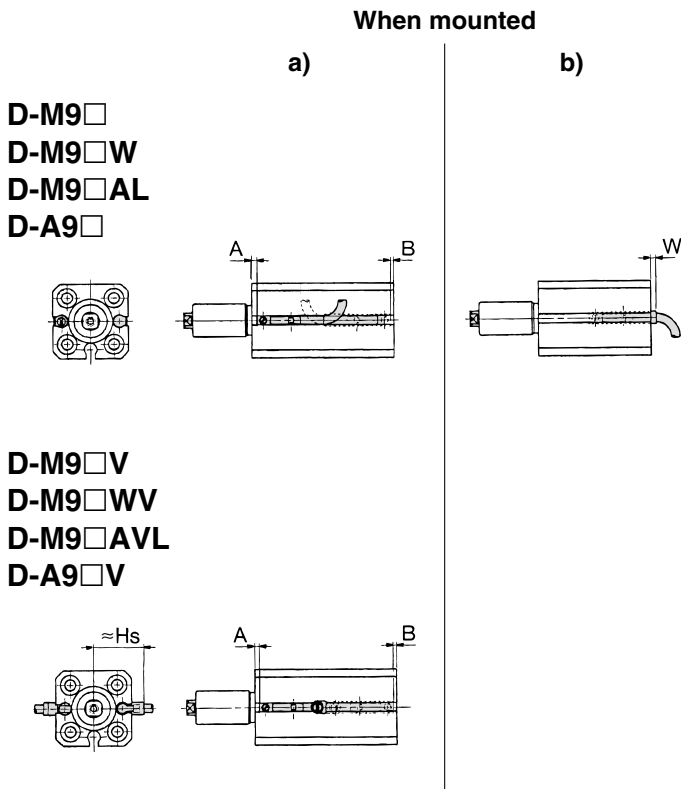

ø16

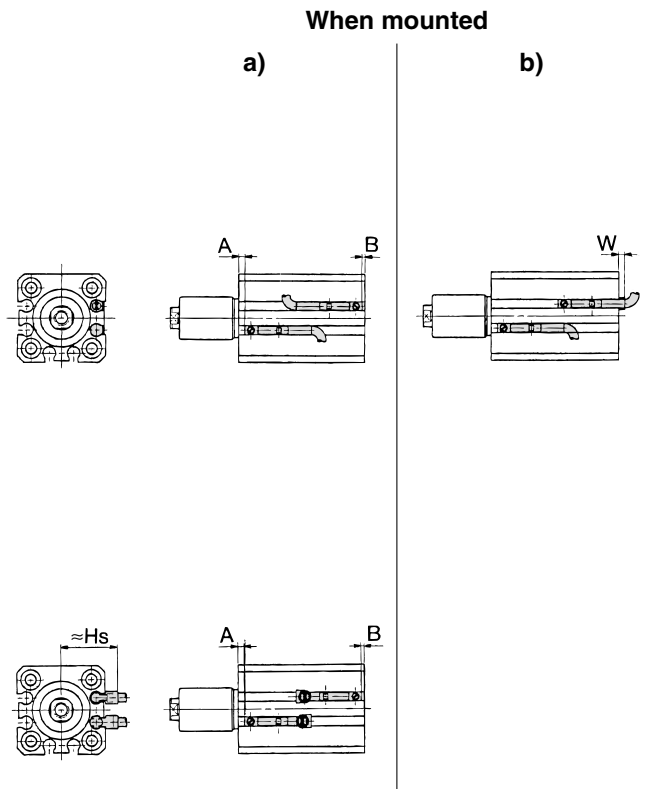

Auto Switch Proper Mounting Position

Bore size (mm)	D-M9□ D-M9□W D-M9□AVL			D-M9□V D-M9□WV			D-M9□AL			D-A9□ D-A9□V		
	A	B	W	A	B	W	A	B	W	A	B	W
12	12	4	6	12	4	4	12	4	8	8	0	4.5 (2)
16	12	4	6	12	4	4	12	4	8	8	0	4.5 (2)

Note 1) (): D-A96, A9□V

Note 2) When setting an auto switch, confirm the operation and adjust its mounting position.

Auto Switch Mounting Height

Auto switch model	D-M9□V D-M9□WV D-M9□AVL		D-A9□V
	Hs		Hs
Bore size			
12	19		17
16	21		19

Operating Range

Auto switch model	Bore size (mm)								
	12	16	20	25	32	40	50	63	
D-M9□/M9□V D-M9□W/M9□WV D-M9□AL/M9□AVL	3	4	5	5.5	5	5	5	6.5	
D-A9□/A9□V	6	7.5	10	9	9	9.5	9.5	11	
D-F7□/J79 D-F7□V/J79C D-F7□W/F7□WV D-J79W D-F79F/F7BAL D-F7BAVL/F7NTL	—	—	6	6	6	6.5	6.5	7.5	
D-A7□/A80 D-A7□H/A80H D-A73C/A80C	—	—	12	11	10.5	11.5	11	13	
D-A79W	—	—	15.5	14	14	15.5	14.5	17	
D-P3DWL	—	—	—	—	6.5	7	7	8	

* Since this is a guideline including hysteresis, not meant to be guaranteed (assuming approximately ±30% dispersion). There may be the case it will vary substantially depending on the ambient environment.

* The D-M9□(V), M9□W(V), M9□A(V)L, and A9□(V) with ø12 or ø16 (MK), or ø32 or more (MK, MK2) indicate the operating range when using the existing auto switch mounting groove, without using auto switch mounting bracket BQ2-012.

D-M9□
D-M9□V
D-M9□W
D-M9□WV

D-M9□AL
D-M9□AVL
D-A9□
D-A9□V

∅20, ∅25

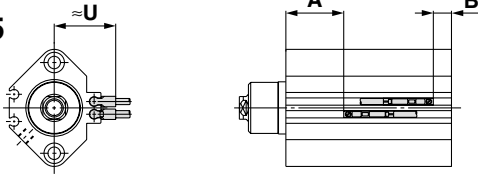

∅32 to ∅63

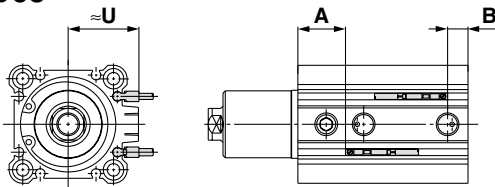

D-F7□/J79
D-F7□V
D-J79C
D-F7□W/J79W
D-F7□WV
D-F7BAL/F7BAVL

D-F79F/F7NTL
D-A7□/A80
D-A73C/A80C
D-A7□H/A80H
D-A79W

∅20, ∅25

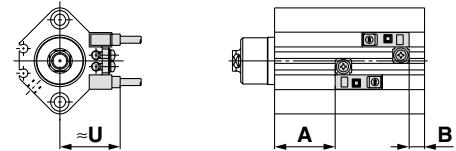

∅32 to ∅63

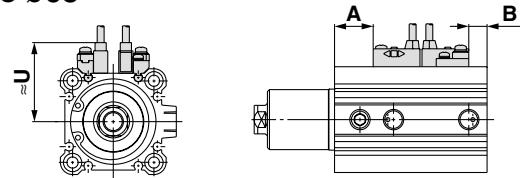

D-P3DWL
∅32 to ∅63

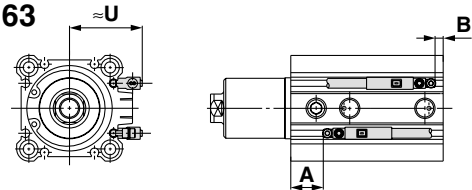

Auto Switch Proper Mounting Position

Bore size (mm)	D-M9□ D-M9□V D-M9□W D-M9□WV D-M9□AL D-M9□AVL		D-F7□/J79 D-F7□V D-J79C/F7□W D-F7□WV D-F7BAL D-F7BAVL D-F79F/J79W D-A7□H/A80H D-A73C/A80C D-A72		D-F7NTL		D-A9□ D-A9□V		D-A73 D-A80		D-A79W		D-P3DWL	
	A	B	A	B	A	B	A	B	A	B	A	B	A	B
20	30.5	10.0	28.0	7.5	33.0	12.5	26.5	6.0	27.5	7.0	25.0	4.5	—	—
25	29.5	12.0	27.0	9.5	32.0	14.5	25.5	8.0	26.5	9.0	24.0	6.5	—	—
32	31.5	13.0	29.0	10.5	34.0	15.5	27.5	9.0	28.5	10.0	26.0	7.5	22.5	3.5
40	25.0	13.0	22.5	10.5	27.5	15.5	21.0	9.0	22.0	10.0	19.5	7.5	16.0	4.0
50	29.0	16.5	26.5	14.0	31.5	19.0	25.0	12.5	26.0	13.5	23.5	11.0	20.0	7.5
63	29.5	19.5	27.0	17.0	32.0	22.0	25.5	15.5	26.5	16.5	24.0	14.0	20.5	10.5

Note) When setting an auto switch, confirm the operation and adjust its mounting position.

Auto Switch Mounting Height

Auto switch model	(mm)									
	D-M9□V	D-A9□V	D-F7□/J79 D-F7□W D-J79W D-F7BAL D-F79F D-F7NTL D-A7□H D-A80H	D-F7□V D-F7□WV	D-J79C	D-A7□ D-A80	D-A73C D-A80C	D-A79W	D-P3DW□	
Bore size	U	U	U	U	U	U	U	U	U	U
20	25	23	25.5	27.5	30	24.5	31	28	—	
25	28	26	28	30.5	32.5	27.5	34	31	—	
32	28.5	26.5	36	26.5	39.5	34	40.5	37.5	33	
40	32	30	38	40	42.5	37.5	43.5	40.5	36.5	
50	37.5	35	43.5	45	48	43	49	46	42	
63	42.5	40.5	48.5	50.5	53.5	48	54.5	51.5	47	

Auto Switch Mounting Bracket/Parts No.

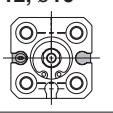
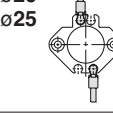
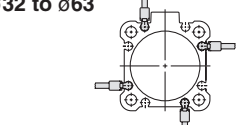
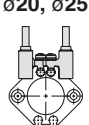
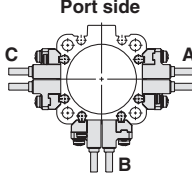
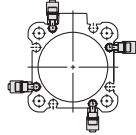
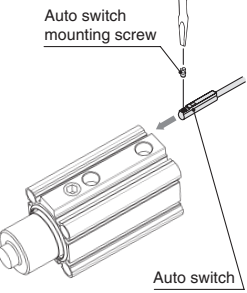
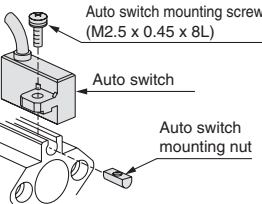
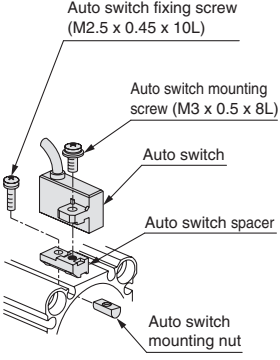
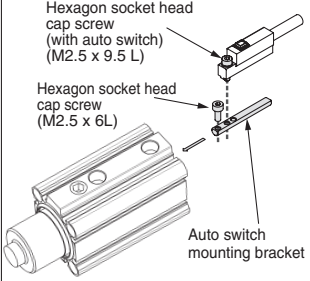
Applicable auto switch	D-M9□/M9□V D-M9□W/M9□WV D-M9□AL/M9□AVL D-A9□/A9□V	D-F7□/F7□V/J79/J79C/F7□W/J79W/F7□WV D-F7BAL/F7BAVL/F79F/F7NTL D-A7□/A80/A7□H/A80H/A73C/A80C/A79W		D-P3DW□								
Bore size (mm)	ø12 to ø63	ø20, ø25	ø32 to ø63	ø32 to ø63								
Auto switch mounting bracket part no.	—	BQ4-012	BQ5-032	BQ6-032S								
Auto switch mounting bracket fitting parts lineup/weight	—	<ul style="list-style-type: none"> Auto switch mounting screw (M2.5 x 8L) Auto switch mounting nut Weight: 1.5 g 	<ul style="list-style-type: none"> Auto switch fixing screw (M2.5 x 10L) Auto switch mounting screw (M3 x 8L) Auto switch spacer Auto switch mounting nut Weight: 3.5 g 	<ul style="list-style-type: none"> Hexagon socket head cap screw (M2.5 x 6L) Auto switch mounting bracket (nut) Weight: 5 g 								
		When requesting the enclosure of the auto switch mounting bracket with the cylinder for shipment, add “-BQ” to the end of the cylinder part number. Standard model no. +BQ Example: MKB20-10LZ-BQ										
Auto switch mounting surface	Surfaces with auto switch mounting slot ø12, ø16  ø20 ø25  ø32 to ø63 	Auto switch mounting rail side only — 	A/B/C side except port side 	Surfaces with auto switch mounting slot 								
Mounting of auto switch	 <p>Auto switch mounting screw</p> <p>Auto switch</p> <ul style="list-style-type: none"> When tightening the auto switch mounting screw, use a watchmakers' screwdriver with a handle 5 to 6 mm in diameter. <p>Tightening torque of auto switch mounting screw (N·m)</p> <table border="1"> <thead> <tr> <th>Auto switch model</th> <th>Tightening torque</th> </tr> </thead> <tbody> <tr> <td>D-M9□(V)</td> <td rowspan="3">0.05 to 0.15</td> </tr> <tr> <td>D-M9□W(V)</td> </tr> <tr> <td>D-M9□A(V)L</td> </tr> <tr> <td>D-A9□(V)</td> <td>0.10 to 0.20</td> </tr> </tbody> </table>	Auto switch model	Tightening torque	D-M9□(V)	0.05 to 0.15	D-M9□W(V)	D-M9□A(V)L	D-A9□(V)	0.10 to 0.20	<ol style="list-style-type: none"> Insert the nut into the auto switch mounting slot on the cylinder tube, and place it in the roughly estimated setting position. Engage the ridge on the auto switch mounting arm with the recess in the cylinder tube rail, and slide it to the position of the nut. Gently screw the auto switch mounting screw into the thread of the auto switch mounting nut through the mounting hole on the auto switch mounting arm. Confirm where the mounting position is, and tighten the auto switch mounting screw to fix the auto switch. The tightening torque of the M2.5 screw must be 0.25 to 0.35 N·m. The detection position can be changed under the conditions in step ③.  <p>Auto switch mounting screw (M2.5 x 0.45 x 8L)</p> <p>Auto switch</p> <p>Auto switch mounting nut</p>	<ol style="list-style-type: none"> Insert the nut into the auto switch mounting slot on the cylinder tube, and place it in the roughly estimated setting position. With the lower tapered part of the auto switch spacer facing the outside of the cylinder tube, line up the M2.5 through hole with the M2.5 female of the auto switch mounting nut. Gently screw the auto switch mounting nut fixing screw (M2.5) into the thread of the auto switch mounting nut through the mounting hole. Engage the ridge on the auto switch mounting arm with the recess in the auto switch spacer. Tighten the auto switch mounting screw (M3) to fix the auto switch. The tightening torque of the M3 screw must be 0.35 to 0.45 N·m. Confirm where the mounting position is, and tighten the auto switch fixing screw (M2.5) to fix the auto switch mounting nut. The tightening torque of the M2.5 screw must be 0.25 to 0.35 N·m. The detection position can be changed under the conditions in step ⑤.  <p>Auto switch fixing screw (M2.5 x 0.45 x 10L)</p> <p>Auto switch mounting screw (M3 x 0.5 x 8L)</p> <p>Auto switch</p> <p>Auto switch spacer</p> <p>Auto switch mounting nut</p>	<ol style="list-style-type: none"> Fix the auto switch and the auto switch mounting bracket temporarily by tightening the attached hexagon socket head cap screw (M2.5 x 9.5 L) 1 to 2 turns. Insert the temporarily tightened mounting bracket into the mating groove of the cylinder tube, and slide the auto switch onto the cylinder tube through the groove. Insert the auto switch onto the cylinder/actuator through the groove with the back part of the auto switch (lead wire side) and the back part of the auto switch mounting bracket. Check the detecting position of the auto switch and fix the auto switch firmly with the hexagon socket head cap screw (M2.5 x 6L, M2.5 x 9.5L)*. If the detecting position is changed, go back to step ②. <p>*The hexagon socket head cap screw (M2.5 x 6L) is used to fix the mounting bracket and cylinder tube. This enables the replacement of the auto switch without adjusting the auto switch position.</p> <p>Note 1) Ensure that the auto switch is covered with the mating groove to protect the auto switch.</p> <p>Note 2) The tightening torque of the hexagon socket head cap screw (M2.5 x 6L, M2.5 x 9.5L) is 0.2 to 0.3 N·m.</p> <p>Note 3) Tighten the hexagon socket head cap screws evenly.</p>  <p>Hexagon socket head cap screw (with auto switch) (M2.5 x 9.5 L)</p> <p>Hexagon socket head cap screw (M2.5 x 6L)</p> <p>Auto switch mounting bracket</p>
Auto switch model	Tightening torque											
D-M9□(V)	0.05 to 0.15											
D-M9□W(V)												
D-M9□A(V)L												
D-A9□(V)	0.10 to 0.20											

Note) The auto switch mounting bracket and auto switch are enclosed with the cylinder for shipment.

Other than the models listed in "How to Order", the following auto switches are applicable.
For detailed specifications, refer to Best Pneumatics No. 3.

Auto switch type	Model	Electrical entry	Features	Applicable bore size
Reed	D-A72, A73	Grommet (Perpendicular)	—	ø20 to ø63
	D-A80		Without indicator light	
	D-A79W		Diagnostic indication (2-color indication)	
	D-A73C	Connector (Perpendicular)	—	
	D-A80C		Without indicator light	
	D-A72H, A73H, A76H	Grommet (In-line)	—	
	D-A80H		Without indicator light	
Solid state	D-F7NV, F7PV, F7BV	Grommet (Perpendicular)	—	ø20 to ø63
	D-F7NWV, F7BWV		Diagnostic indication (2-color indication)	
	D-F7BAVL		Water resistant (2-color indication)	
	D-J79C	Connector (Perpendicular)	—	
	D-F79, F7P, J79	Grommet (In-line)	—	
	D-F79W, F7PW, J79W		Diagnostic indication (2-color indication)	
	D-F7BAL		Water resistant (2-color indication)	
	D-F79F		With diagnostic output (2-color indication)	
	D-F7NTL		With timer	

* With pre-wired connector is also available for solid state auto switches. For details, refer to Best Pneumatics No. 3.

Mounting

⚠ Caution

When a Magnetic Body Surrounds the Cylinder

- When a magnetic body surrounds the cylinder as shown in the figure below (including when the magnetic body is only on one side of the cylinder), the movement of the auto switch may become unstable, so please contact SMC.

ø12 to ø16
ø32 to ø63

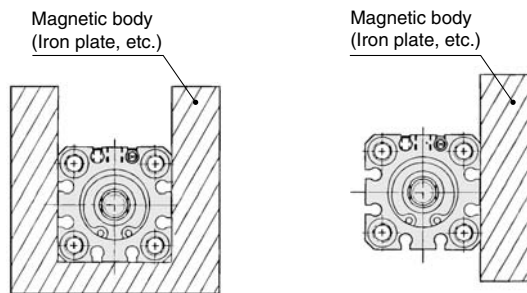

ø20, ø25

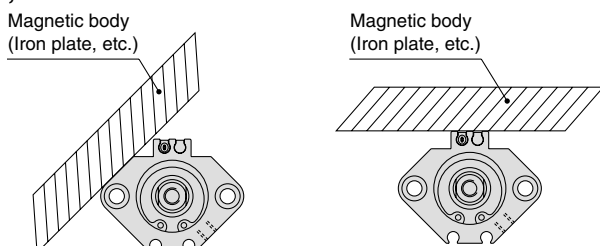

With Magnetic Field Resistant Auto Switch D-P3DWL

- If welding cables or welding gun electrodes are in the vicinity of the cylinder, the magnets in the cylinder could be affected by the external magnetic fields. (Please contact SMC if the welding amperage exceeds 16000 A.) If the source of strong magnetism comes in contact with the cylinder or an auto switch, make sure to install the cylinder away from the source of the magnetism.
If the cylinder is to be used in an environment in which spatter will come in direct contact with the lead wires, cover the lead wires with a protective tube. For the protective tube, use a tube I.D. ø7 or more, which excels in heat resistance and flexibility. Please contact SMC if an inverter welder or a DC welder will be used.

Auto Switch Connections and Examples

Basic Wiring

Solid state 3-wire, NPN

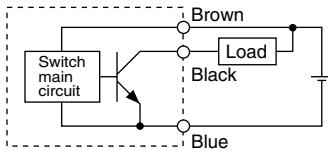

Solid state 3-wire, PNP

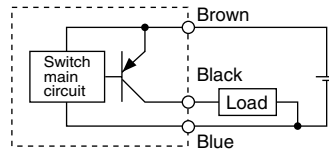

2-wire (Solid state)

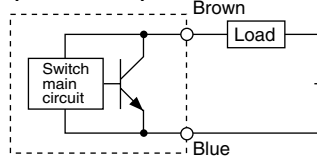

2-wire (Reed)

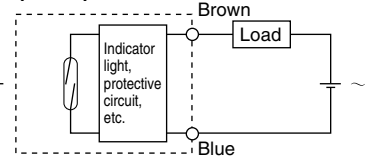

(Power supplies for switch and load are separate.)

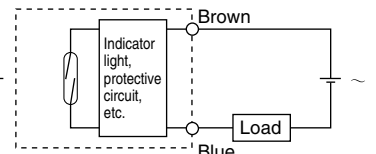
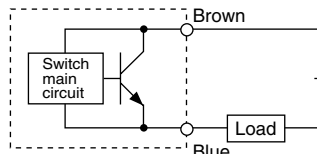
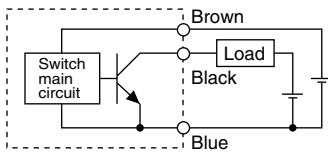

Example of Connection to PLC (Programmable Logic Controller)

• Sink input specification 3-wire, NPN

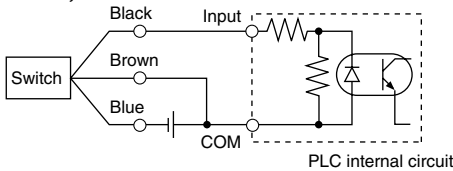

• Source input specification 3-wire, PNP

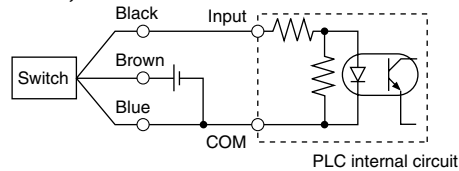

Connect according to the PLC input specifications, since the connection method will differ depending on the PLC input specifications.

2-wire

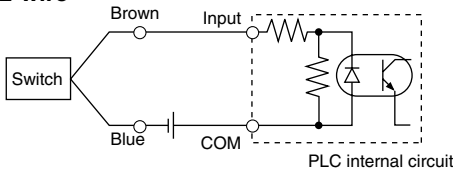

2-wire

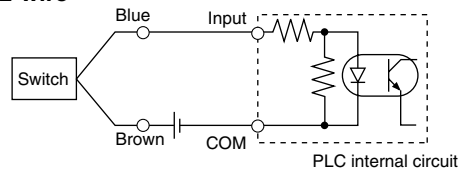

Example of AND (Serial) and OR (Parallel) Connection

• 3-wire

AND connection for NPN output (using relays)

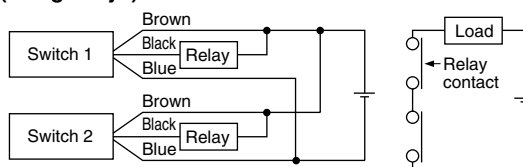

AND connection for NPN output (performed with switches only)

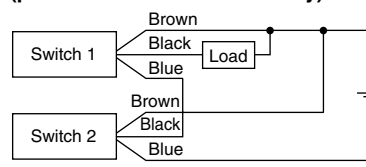

OR connection for NPN output

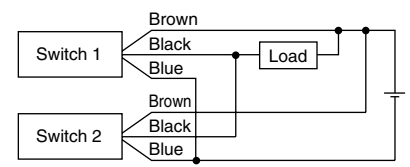

The indicator lights will illuminate when both switches are turned ON.

• 2-wire

2-switch AND connection

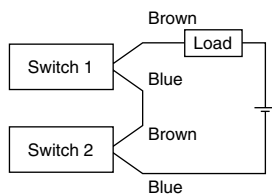

When two switches are connected in series, a load may malfunction because the load voltage will decrease in the ON state. The indicator lights will illuminate if both switches are turned ON.

$$\begin{aligned} \text{Load voltage at ON} &= \text{Power supply voltage} - \text{Residual voltage} \times 2 \text{ pcs.} \\ &= 24 \text{ V} - 4 \text{ V} \times 2 \text{ pcs.} \\ &= 16 \text{ V} \end{aligned}$$

Example) Power supply voltage: 24 VDC
Auto switch internal voltage drop: 4 V

2-switch OR connection

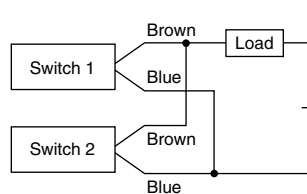

(Solid state)

When two switches are connected in parallel, malfunction may occur because the load voltage will increase in the OFF state.

$$\begin{aligned} \text{Load voltage at OFF} &= \text{Leakage current} \times 2 \text{ pcs.} \\ &\quad \times \text{Load impedance} \\ &= 1 \text{ mA} \times 2 \text{ pcs.} \times 3 \text{ k}\Omega \\ &= 6 \text{ V} \end{aligned}$$

Example) Load impedance: 3 kΩ
Auto switch leakage current: 1 mA

(Reed)

Because there is no leakage current, the load voltage will not increase in the OFF state. However, depending on the number of switches in the ON state, the indicator lights may sometimes dim or not light because of the dispersion and reduction of the current flowing to the switches.

Rotary Clamp Cylinder Series MK

Made to Order Individual Specifications



Please contact SMC for detailed dimensions, specifications, and lead times.

Max. Operating Pressure 1.0 MPa **Symbol -X2071**

MK **Mounting** 63 - **Stroke** **Rotary direction** N Z - **X2071**

- Use this specification if the pressure is between 0.61 and 1.0 MPa when using MK□63-□□Z.
- The rod end and arm dimensions are different from the standard.
- When an arm assembly is ordered for this specification, order it with the part number [MK-A063-X2071]. (See below.)

Body option	
Nil	Without arm
N	With arm

Max. operating pressure 1.0 MPa

Specifications

Bore size (mm)	63
Operating pressure range	0.1 to 1.0 MPa

* Specifications other than the above are the same as the standard.

Construction/Dimensions (The outline dimensions shown are when the rod is retracted.)
Dimensions other than those marked with "*" are the same as the standard.

Without arm

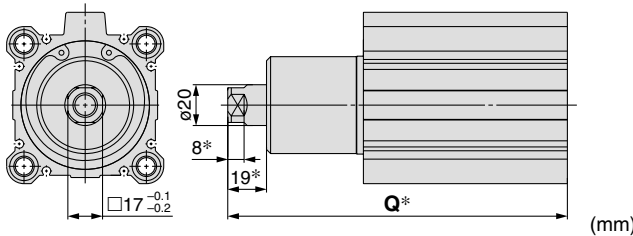

Model	Rod state	Q			
		Clamp stroke			
		10 mm	20 mm	30 mm	50 mm
MK□63-□Z-X2071	Retracted	146.5	166.5	186.5	226.5
	Extended	175.5	205.5	235.5	295.5

With arm

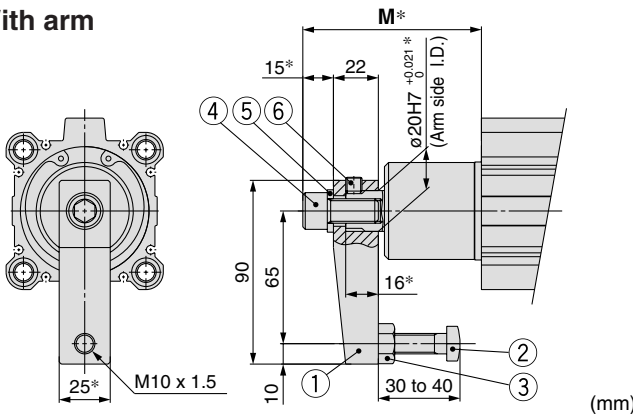

Model	Rod state	M			
		Clamp stroke			
		10 mm	20 mm	30 mm	50 mm
MK□63-□Z-X2071	Retracted	77.5	87.5	97.5	117.5
	Extended	106.5	126.5	146.5	186.5

Arm assembly MK-A063-X2071

Max. operating pressure 1.0 MPa

Arm Assembly Component Parts

No.	Description	Material	Note
1	Arm	Rolled steel	
2	Clamp bolt	Chromium molybdenum steel	
3	Hexagon nut	Rolled steel	
4	Hexagon socket head cap screw	Chromium molybdenum steel	M12 x 25L
5	Spring washer	Hard steel	
6	Hexagon socket head set screw	Chromium molybdenum steel	Flat point M8 x 8L

* The arm assembly consists of the parts No.1 to 6.

Overall Length Is the Same as the MK2 Series **Symbol -X2094**

MK **Mounting** **Bore size** - **Stroke** **Rotary direction** **Body option** Z - **X2094**

Overall length is the same as the MK2 series

- The overall length Q (from the end on the head side to the rod end) is the same as the MK2 series.

Applicable bore size/Stroke

Bore size	Stroke
ø20	10, 20
ø25	
ø32	
ø40	
ø50	20, 50
ø63	

Dimensions (The outline dimensions shown are when the rod is retracted.)
Dimensions other than those marked with "*" are the same as the standard.

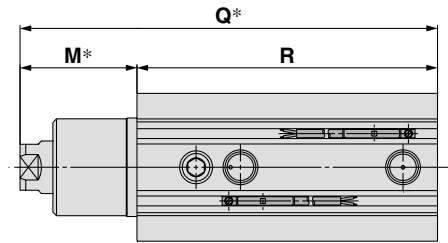

Bore size	Rod state	Clamp stroke								
		10 mm			20 mm			50 mm		
		Q	R	M	Q	R	M	Q	R	M
ø20	Retracted	95.5	72	23.5	115.5	82	33.5	—	—	—
	Extended	115	72	43	145	82	63	—	—	—
ø25	Retracted	98.5	73	25.5	118.5	83	35.5	—	—	—
	Extended	118	73	45	148	83	65	—	—	—
ø32	Retracted	121.5	81.5	40	141.5	91.5	50	—	—	—
	Extended	146.5	81.5	65	176.5	91.5	85	—	—	—
ø40	Retracted	122.5	75	47.5	142.5	85	57.5	—	—	—
	Extended	147.5	75	72.5	177.5	85	92.5	—	—	—
ø50	Retracted	—	—	—	162	96.5	65.5	222	126.5	95.5
	Extended	—	—	—	201	96.5	104.5	291	126.5	164.5
ø63	Retracted	—	—	—	165	100	65	225	130	95
	Extended	—	—	—	204	100	104	294	130	164



Safety Instructions

These safety instructions are intended to prevent hazardous situations and/or equipment damage. These instructions indicate the level of potential hazard with the labels of “**Caution**,” “**Warning**” or “**Danger**.” They are all important notes for safety and must be followed in addition to International Standards (ISO/IEC)*1, and other safety regulations.



Caution:

Caution indicates a hazard with a low level of risk which, if not avoided, could result in minor or moderate injury.



Warning:

Warning indicates a hazard with a medium level of risk which, if not avoided, could result in death or serious injury.



Danger:

Danger indicates a hazard with a high level of risk which, if not avoided, will result in death or serious injury.

- *1) ISO 4414: Pneumatic fluid power – General rules relating to systems.
 ISO 4413: Hydraulic fluid power – General rules relating to systems.
 IEC 60204-1: Safety of machinery – Electrical equipment of machines.
 (Part 1: General requirements)
 ISO 10218-1: Manipulating industrial robots - Safety.
 etc.



Warning

1. The compatibility of the product is the responsibility of the person who designs the equipment or decides its specifications.

Since the product specified here is used under various operating conditions, its compatibility with specific equipment must be decided by the person who designs the equipment or decides its specifications based on necessary analysis and test results. The expected performance and safety assurance of the equipment will be the responsibility of the person who has determined its compatibility with the product. This person should also continuously review all specifications of the product referring to its latest catalog information, with a view to giving due consideration to any possibility of equipment failure when configuring the equipment.

2. Only personnel with appropriate training should operate machinery and equipment.

The product specified here may become unsafe if handled incorrectly. The assembly, operation and maintenance of machines or equipment including our products must be performed by an operator who is appropriately trained and experienced.

3. Do not service or attempt to remove product and machinery/equipment until safety is confirmed.

1. The inspection and maintenance of machinery/equipment should only be performed after measures to prevent falling or runaway of the driven objects have been confirmed.
2. When the product is to be removed, confirm that the safety measures as mentioned above are implemented and the power from any appropriate source is cut, and read and understand the specific product precautions of all relevant products carefully.
3. Before machinery/equipment is restarted, take measures to prevent unexpected operation and malfunction.

4. Contact SMC beforehand and take special consideration of safety measures if the product is to be used in any of the following conditions.

1. Conditions and environments outside of the given specifications, or use outdoors or in a place exposed to direct sunlight.
2. Installation on equipment in conjunction with atomic energy, railways, air navigation, space, shipping, vehicles, military, medical treatment, combustion and recreation, or equipment in contact with food and beverages, emergency stop circuits, clutch and brake circuits in press applications, safety equipment or other applications unsuitable for the standard specifications described in the product catalog.
3. An application which could have negative effects on people, property, or animals requiring special safety analysis.
4. Use in an interlock circuit, which requires the provision of double interlock for possible failure by using a mechanical protective function, and periodical checks to confirm proper operation.



Caution

1. The product is provided for use in manufacturing industries.

The product herein described is basically provided for peaceful use in manufacturing industries.

If considering using the product in other industries, consult SMC beforehand and exchange specifications or a contract if necessary.

If anything is unclear, contact your nearest sales branch.

Limited warranty and Disclaimer/ Compliance Requirements

The product used is subject to the following “Limited warranty and Disclaimer” and “Compliance Requirements”.

Read and accept them before using the product.

Limited warranty and Disclaimer

1. The warranty period of the product is 1 year in service or 1.5 years after the product is delivered.*2)
 Also, the product may have specified durability, running distance or replacement parts. Please consult your nearest sales branch.
2. For any failure or damage reported within the warranty period which is clearly our responsibility, a replacement product or necessary parts will be provided.
 This limited warranty applies only to our product independently, and not to any other damage incurred due to the failure of the product.
3. Prior to using SMC products, please read and understand the warranty terms and disclaimers noted in the specified catalog for the particular products.

*2) Vacuum pads are excluded from this 1 year warranty.

A vacuum pad is a consumable part, so it is warranted for a year after it is delivered.

Also, even within the warranty period, the wear of a product due to the use of the vacuum pad or failure due to the deterioration of rubber material are not covered by the limited warranty.

Compliance Requirements

1. The use of SMC products with production equipment for the manufacture of weapons of mass destruction (WMD) or any other weapon is strictly prohibited.
2. The exports of SMC products or technology from one country to another are governed by the relevant security laws and regulations of the countries involved in the transaction. Prior to the shipment of a SMC product to another country, assure that all local rules governing that export are known and followed.



Safety Instructions

Be sure to read “Handling Precautions for SMC Products” (M-E03-3) before using.

SMC Corporation

Akihabara UDX 15F,
4-14-1, Sotokanda, Chiyoda-ku, Tokyo 101-0021, JAPAN
Phone: 03-5207-8249 Fax: 03-5298-5362
URL <http://www.smcworld.com>

© 2009 SMC Corporation All Rights Reserved

Specifications are subject to change without prior notice and any obligation on the part of the manufacturer.

D-DN

1st printing NZ printing NZ 6000SZ Printed in Japan.

This catalog is printed on recycled paper with concern for the global environment.